

Journée Lauric GARBUIO – 11/10/23

Vincent DEBUSSCHERE

Développements réellement durables
*Des solutions fiables et robustes
du composant aux systèmes*

Travaux communs



- Kevin BANJAR-NAHOR (2015-2019)
- Kathleen Mallard (2016-2020)
- Audrey Moulichon (2017-2019)
- Hassan Issa (2021-2024)



Vidéo de Kevin





Economic
Financial perspective
Job creation
Economic environment
Household budget

Social
Community development, involvement
Capacity strengthening
Education
Client relation
Security, safety

Environmental
Global impact
Local impact

Technical
Fabrication
Installation
Operation
Maintenance
End of life

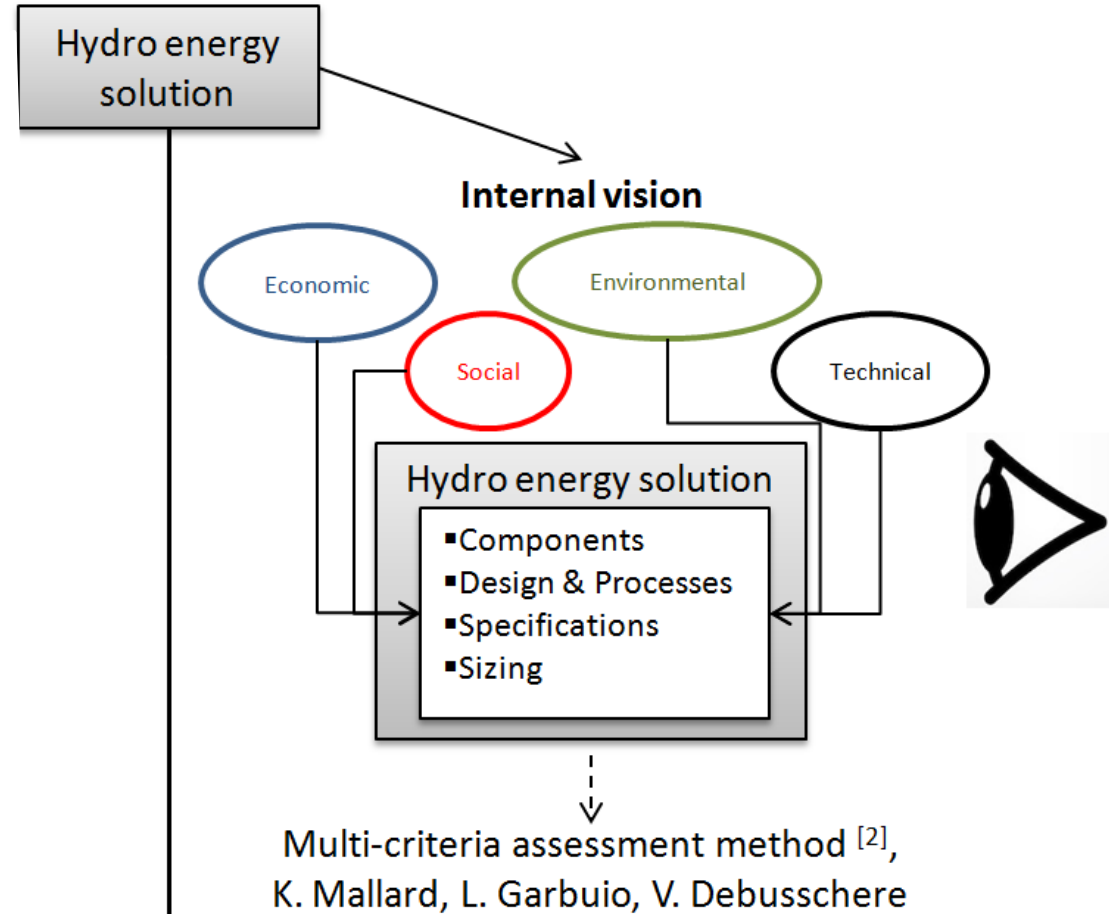
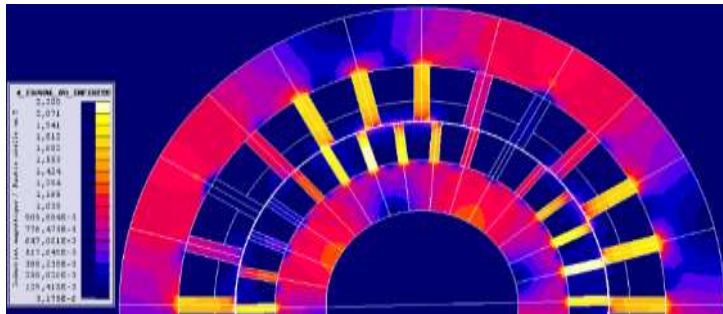

Audrey Moulichon

Machine synchrone virtuelle adaptative pour microgrids 100% renouvelables

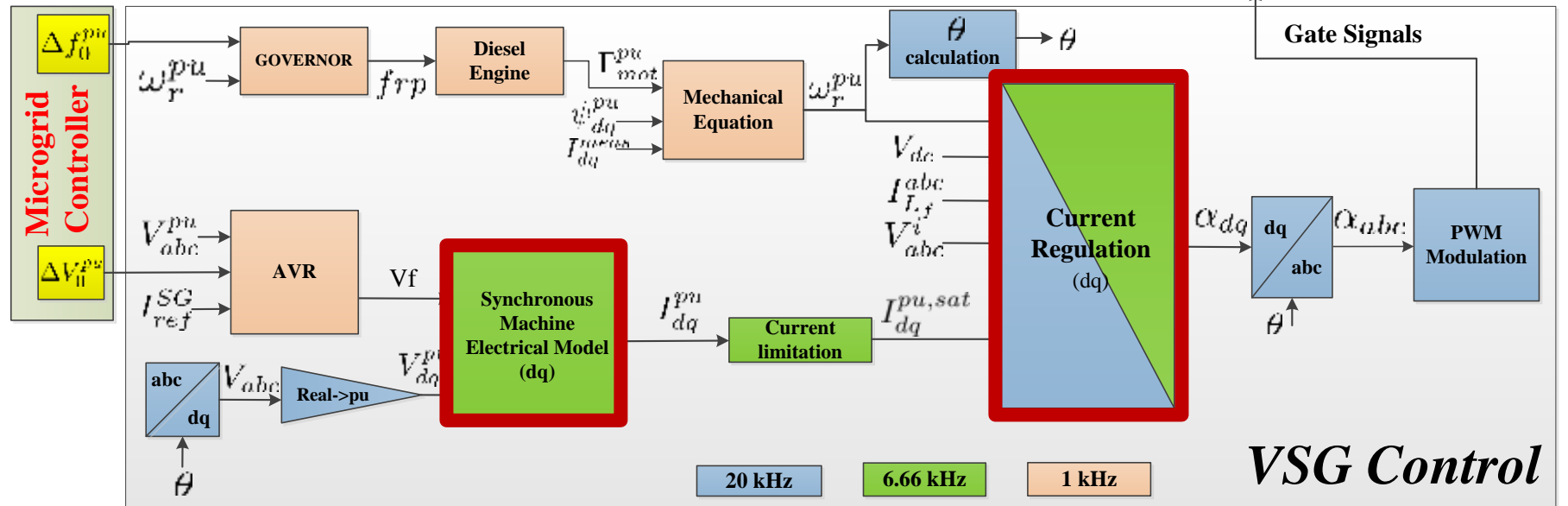
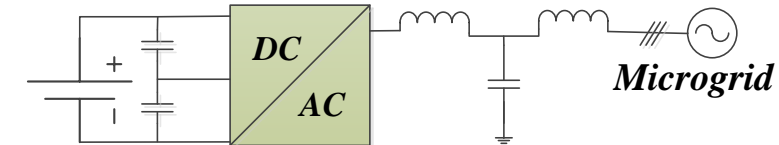
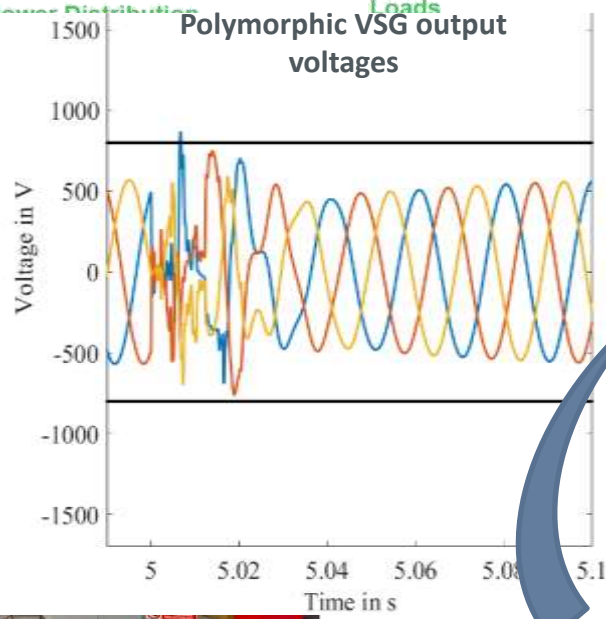
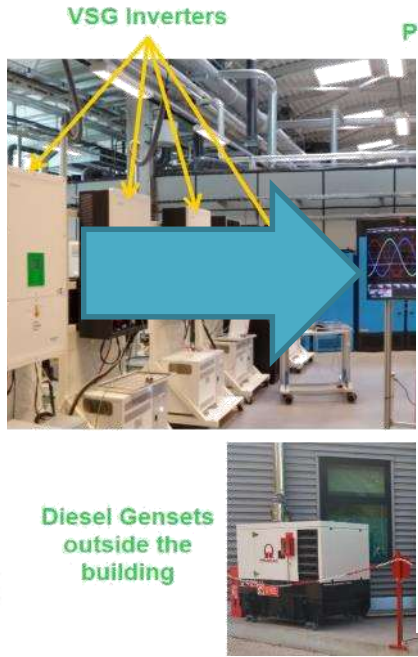
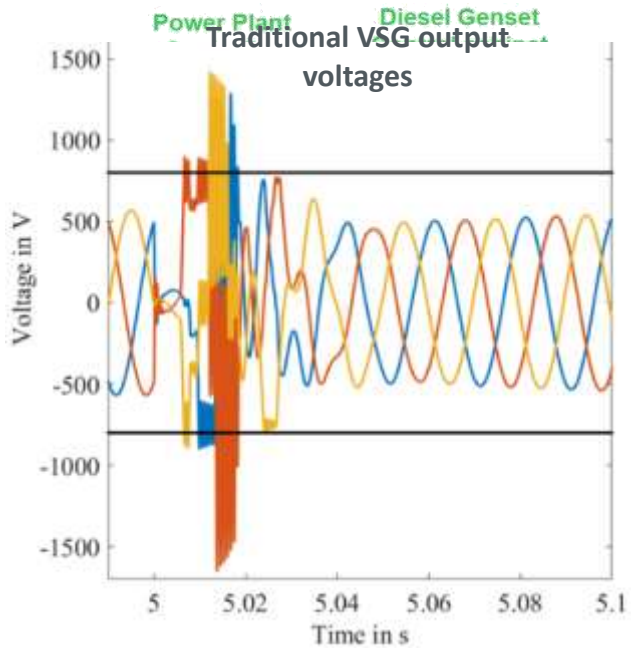

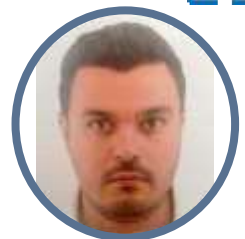
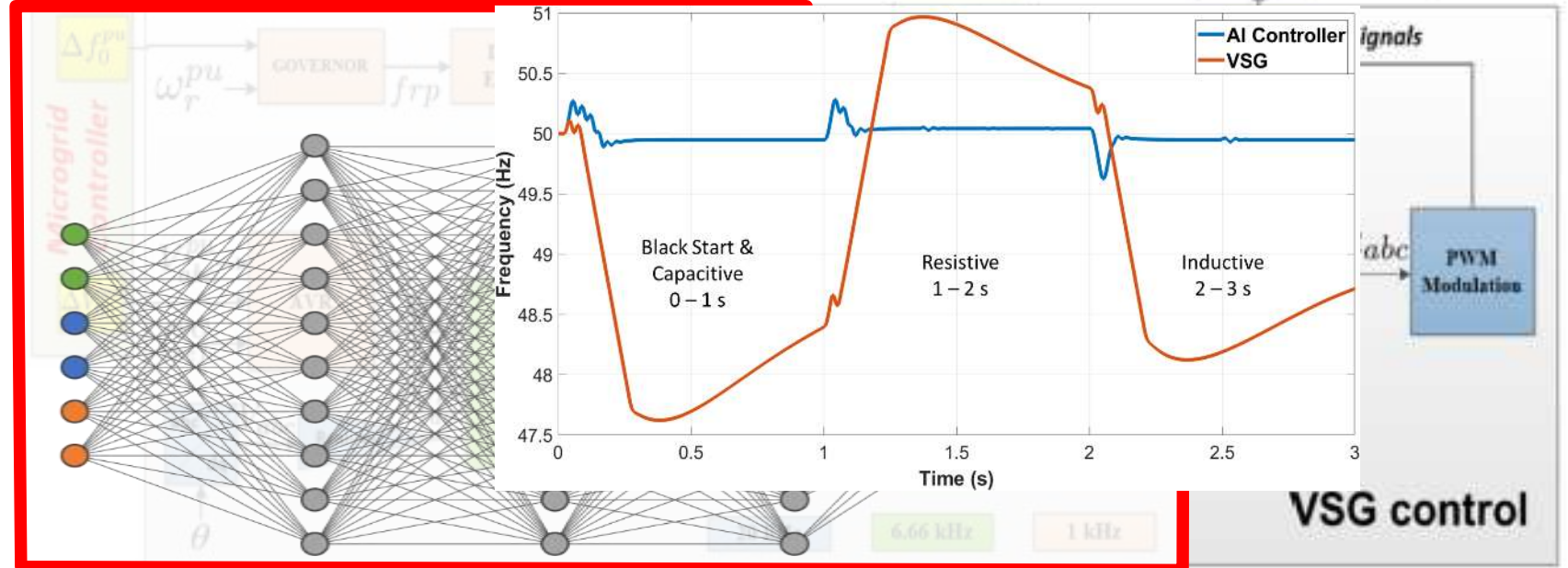
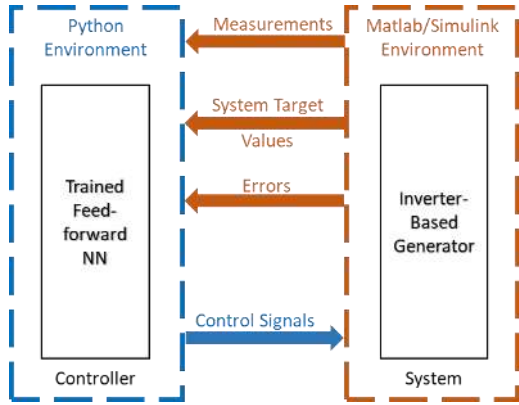
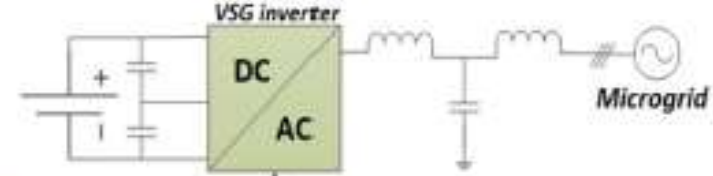
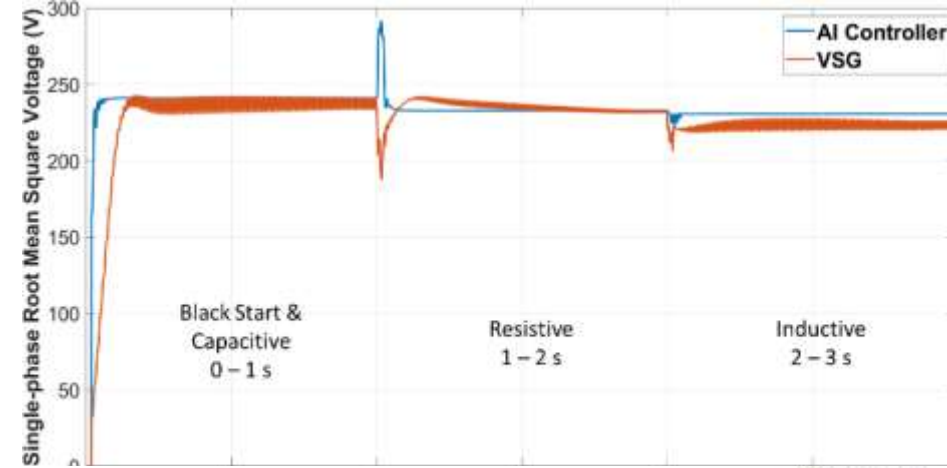
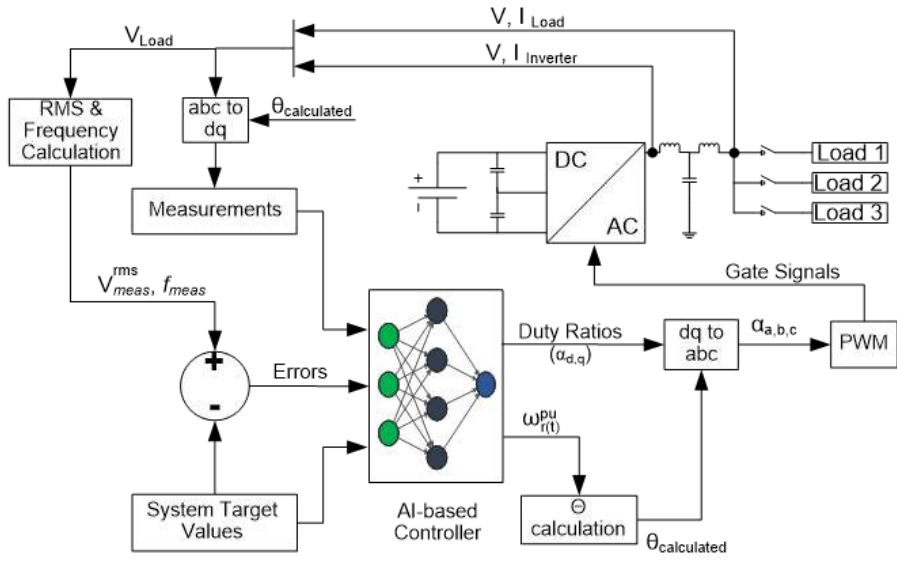

Fulgurances et foisonnement d'idées





Merci